

View A Type I

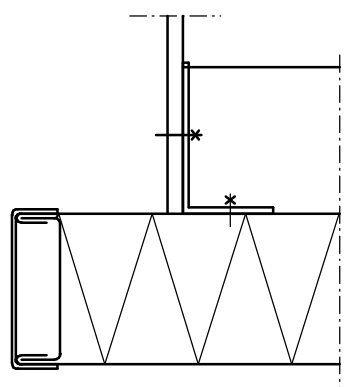

View A Type II

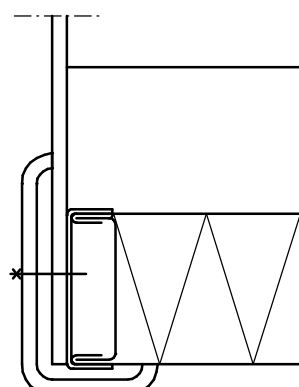

View A Type III

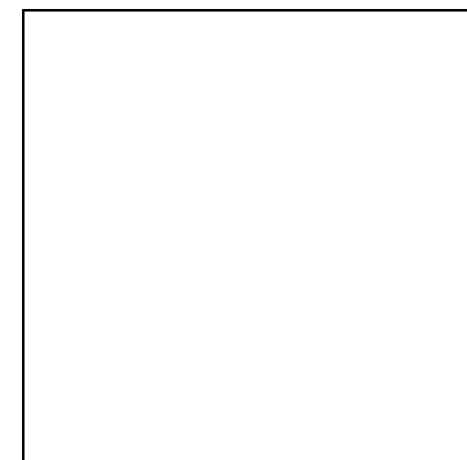
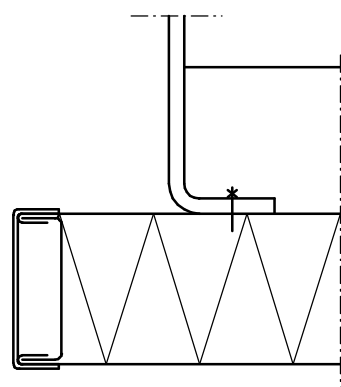

R.f.I C.1



LUBMOR Ltd.

ul. Wieleńska 1, 64-980 Trzcianka
 tel. +48/67/216-22-44
 fax +48/67/216-59-40
 e-mail: marketing@lubmor.pl
 e-mail: konstrukcja@lubmor.pl

COMPENSATIVE GRP WINDOW BOX cl. B0

KK 24-11
35-240

COMPENSATIVE GRP WINDOW BOX cl. B0

APPROPRIATION

Compensative window box is designed for building of fixed windows on all floating objects.

EXECUTION

Subject window box is made of glass reinforced polyester-resins.

This window box is suitable for window of dimensions 960x960mm.

DELIVERY RANG

The window box is delivered without screws and angle bars for its installation (type I).

Delivery comprises the window boxes with flanges but without screws for installation (type II).

Delivery comprises the window boxes without screws for installation (type III).

PACKING, TRANSPORT, STORAGE

The window boxes are protected against mechanical damages, packed with parcels and placed on the pallets for their displacing by means of the fork-lift trucks and the cranes.

DIVISION, MARKING AND FINISHING

Finishing of visible surfaces – gelcoat with colour acc. to RAL catalogue (standard colour – RAL9010)

EXAMPLE OF MARKING

Compensative GRP window box cl. B0 type I for the window with external dimensions 960x960.

COMPENSATIVE GRP WINDOW BOX cl. B0 TYPE I FOR WINDOW 960x960 acc. to catalogue card KK 24-11/35-240.

This catalogue card corresponds with drawing no N 24-09/35-240 .